

OKALUX+ Light Diffusing Insulating Glass

The challenge for OKALUX+ Light Diffusing Insulating Glass: to make daylight useful. With the use of a translucent light diffusing capillary insert (OKAPANE) both sides covered with additional glass fibre tissue inserts in the cavity between panes, OKALUX+ achieves

- optimum, uniform light transmittance into the room, irrespective of irradiation conditions
- light transmission and total solar energy transmittance as required
- good colour rendering
- very good heat insulation
- UV protection as required
- sound insulation as required
- vision protection and glare protection
- slim glass structure, low weight
- visibility for birds

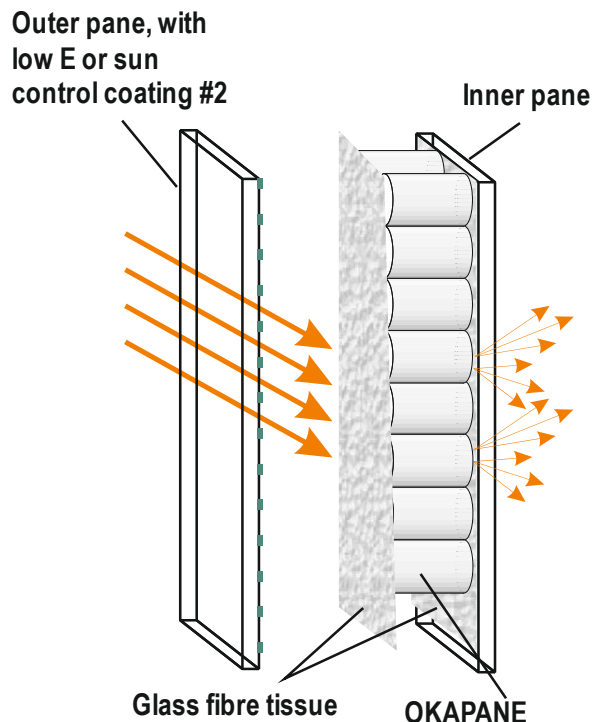

Physical properties

Thermal insulation

The OKAPANE insert reduce the heat transfer in the cavity between panes in terms of convection and heat radiation.

The U_g value for the various versions is dependent, among other things, on:

- the functional coating on surface #2
- the gas filling in the cavity between panes (Air/Argon/Krypton)

The U_g value of insulating glass in accordance with DIN EN 673, DIN EN 674 always relates to vertical installation. If the insulating glass is at an angle, e.g. as in roof glazing, the U_g value increases, because the rising convection level in the cavity between panes increases. Duplex insulating glass with a standard value of $U_g = 1.1 \text{ W/(m}^2\text{K)}$ has an actual value of approx. $1.7 \text{ W/(m}^2\text{K)}$ if used for horizontal roof glazing.

OKAPANE in the cavity between panes prevents convection, which means that the U_g value of OKALUX+ is nearly constant whatever the installation position.

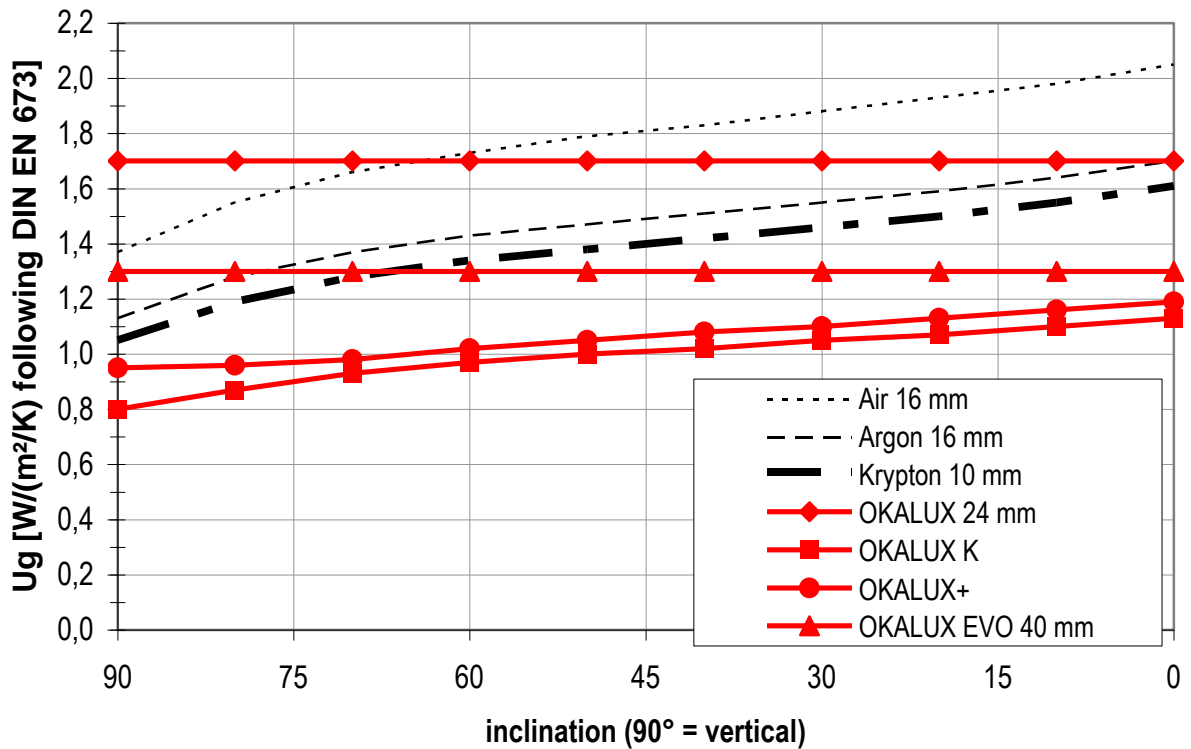

Sound insulation

OKAPANE decouple the panes of the insulating glazing and provide improved sound insulation.

Spectral properties

The special light diffusing properties of the OKAPANE insert provide an optimized, uniform distribution of light in the room, regardless of irradiation conditions.

TSET and light transmission depend on:

- the design of the light-diffusive inserts
- The functional coating on surface #2

The TSET and the light transmission are dependent on the make-up of the light diffusing inserts.

Other TSET and light transmission values can be provided on request with the use of special make-ups.

UV protection

Very low UV transmission possible on request.

Technical values of standard types

The following information applies to a 2-pane make-up consisting a 6 mm external pane with a functional coating on surface #2 and a 4 mm inner pane.

Table 1: Technical values for the 2-pane make-up

OKALUX+	T _v direct %	T _v diffuse %	TSET %	U _g [W/(m ² K)] / U _g [Btu/(hr ft ² °F)] cavity 18 mm		
				Krypton	Argon	Air
39/34	39	30	34	0.9 / 0.16	1.3 / 0.23	1.5 / 0.26
34/21	34	26	21	0.9 / 0.16	1.3 / 0.23	1.5 / 0.26
29/19	29	22	19	0.9 / 0.16	1.3 / 0.23	1.5 / 0.26
24/17	24	18	17	0.9 / 0.16	1.3 / 0.23	1.5 / 0.26
19/14	19	15	14	0.9 / 0.16	1.3 / 0.23	1.5 / 0.26

The following information applies to a 3-pane make-up consisting a 6 mm external pane with a functional coating on surface #2, a 4 mm middle pane and a 4 mm inner pane with a thermal control coating on surface #5.

Table 2: Technical values for the 3-pane make-up

OKALUX+	T _v direct %	T _v diffuse %	TSET %	U _g [W/(m ² K)] / U _g [Btu/(hr ft ² °F)] cavity 18 mm/10 mm	
				Krypton	Argon
32/29	32	24	29	0.5 / 0.09	0.8 / 0.14
28/18	28	22	18	0.5 / 0.09	0.8 / 0.14
24/16	24	18	16	0.5 / 0.09	0.8 / 0.14
20/14	20	15	14	0.5 / 0.09	0.8 / 0.14
16/11	16	12	11	0.5 / 0.09	0.8 / 0.14

Legend and related values:

	unit	standard	technical term
U _g	W/m ² K	DIN EN 673 DIN EN 674	Thermal transmittance
TSET	%	DIN EN 410	Total solar energy transmittance or solar heat gain coefficient
T _v	%	DIN EN 410	Light transmission (direct/hemispheric resp. diffuse/hemispheric)
R _w	dB	DIN EN 20140	Sound reduction coefficient
F _c	%	DIN 4108	Reduction factor of a solar control system, F _c =TSET/TSET _{reference}
SC	%	GANA Manual	Shading coefficient, SC=TSET/0.86

The above data are approximate data. They are based on measurements of approved test institutes and calculations derived from these measurements. Values determined on a project-specific basis may vary from the above values.

Direct transmission relates to direct incidence of light, generally vertical (model situation for direct sun-light). Diffuse transmission applies to homogeneous, diffuse incidence of light from the outer hemisphere (model situation for an overcast sky). All values were measured hemispherically.

A low-e coating or a combined sun-control and low-e coating on surface #2 changes the color appearance.

The specified values may change as a result of technical developments. No guarantee is therefore given for their correctness.

Make-up

What makes OKALUX+ light diffusing insulating glass so special is the OKAPANE inserted in the cavity between the panes. The glass type and thickness vary according to static requirements and design requirements.

Standard make-up:

2-pane make-up

Outer pane with functional coating on surface #2

Cavity 18 mm with

8 mm gas filling

OKAPANE 10 mm covered with glass fibre tissues both sides
additional glass fibre tissue

Inner pane

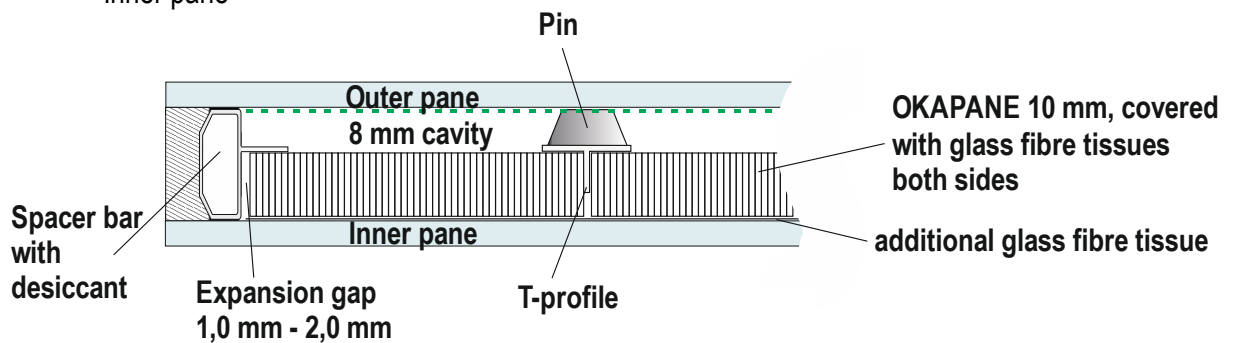

3-pane make-up

Outer pane with functional coating on surface #2

Cavity 1: 18 mm with

8 mm gas filling

OKAPANE 10 mm covered with glass fibre tissues both sides
additional glass fibre tissue

Middle pane

Cavity 2: 10 mm with gas filling

Inner pane with thermal control coating on surface #5

Variations in the density of the OKAPANE and the diameters of the capillaries may be visible, as can joints which are necessary for production reasons. Under certain light conditions it may also be possible that fine lines and wrinkling of the tissues, also the result of the production process, can be seen within the OKAPANE. The physical characteristics of OKALUX+ are not adversely affected by the above.

Dimensions

larger glass dimension	up to 4000 mm	no restrictions
smaller glass dimension	up to 1230 mm	no restrictions
	1231 mm to 2000 mm	subdivision by joint with aluminium profile, through additional glass fibre tissue
minimum size	300 mm x 300 mm	

Max. 1 joint possible.

Standard colour edge profiles: Anodized aluminium E6/C-0 (EV1)

Standard colour joint profile (if needed): White aluminium

For tolerance reason and due to different thermal expansions, the insert may exhibit a visible light gap between the insert and the spacer bar. For this reason, the overall sealant (spacer bar + secondary seal) plus additional 5 mm have to be covered by a profile or by an appropriate edge screen printing.

In the case of a polysulphide as secondary seal, it may be necessary to use a exceed cover in order to provide sufficient UV protection. In the case of a frameless glazing system, it is generally recommended that the edge areas are covered using a UV-impenetrable edge enamelling. Depending on loading, the required sealant width can be considerably greater than that of “conventional” insulating glazing.

Planning instructions

Builder-owners and architects must be able to technically assess the effect of glazing in daylight terms. OKALUX offers such calculations as a voluntary extra service without obligation. The daylight-relevant properties of the room to be examined must be known; in particular, these are:

- room geometry, window dimensions
- approximate degree of reflection of the surfaces forming the room boundaries

The so-called daylight quotient (D) in accordance with DIN 5034, Part 3, is relevant for the evaluation of the ambient daylight. This gives the ratio between the horizontal luminous intensity indoors and out of doors, under a completely overcast sky. This value can be calculated for different glazing variants using the existing simulation tools. The customer can thus assess the light-directing effects of special products, in comparison with normal glazing as well. In addition to the assessment in accordance with DIN, virtual images can visualise the light distribution in the rooms.

Installation instructions

OKALUX+ insulating glass is glazed as per normal insulating glass. During transportation, the insert may slide to the side, creating a greater visible slit between the spacer and the insert or the support profiles could become inclined. We must be notified in writing beforehand of any special loads which may occur during transportation (vibrations/shaking).

For instructions and recommendations for the installation of our insulating glazing, please refer to our information and instructions for customers contained in "Delivery of OKALUX Glass Products" and "General Information on Glazing".

Other printed matter

If you do not have the following printed matter, please request it directly from OKALUX or download it from the Internet at www.okalux.com:

General terms and conditions of business

Product-specific information texts

As well as these, there are the following customer notes:

Customer notes on offers

Customer notes on delivery

Customer notes alarm glass

Customer notes screen printing

Customer notes Structural Glazing / Edge deletion

Customer notes on heat-soak test

Customer notes on glazing

Customer notes SIGNAPUR®

Cleaning instructions for OKALUX gen.

Guideline for visual quality