

# 1. GENERAL

## 1.1 What is BI-StepColor ?

**BI-StepColor** is a walk-on, slip-proof glass with high bearing capacity and many different configurational options. The special glass design permits it to be used as a supporting framework for loads of up to 5 kN/m<sup>2</sup> (see Point 2). **BI-StepColor** features a slip-proof surface which also guarantees a high sliding friction coefficient under various test conditions.

Depending on its application **BI-StepColor** is supplied in several different configurations.

## 1.2 Application classes

The areas of use are subdivided into three application classes:

### Class 1:

Glass with no supporting function

### Class 2:

Glass with a supporting function. Falling height is below the legal building approval requirement.

### Class 3:

Glass with a supporting function. Falling height requires legal building approval <sup>1)</sup>

- Classes 2 and 3 are designed according to the same dimensional criteria.

## The requirements

- **Traffic load**
- **Span width and**
- **Storage, as well as the**
- **Application class**

determine the glass configuration.

The residual supporting capacity (i. e. after the pane itself has been destroyed the function still has to be guaranteed for a certain time) must be proven by trials.

BGT has the results of various trials on residual supporting capacity. In the case of 2-sided support - the glass pane should be screwed to the substructure.

1) General building authority is not available for this at present. However individual approvals must be applied for in the case of specific installations.

## 2. TRAFFIC LOAD AND SPAN WIDTHS

The following tables show maximum span widths depending on the glass configuration and the traffic load. These values are only reference values which cannot be used for structural calculations.

2-sided support:

The values given refer to a span width of 300 mm. If supported on two sides the glass must be mechanically secured.

4-sided support:

For the values given a pane thickness of 300 mm can be assumed.

**Table 1:**

Glass configurations	Application class	Max. supporting width $l_s$ at traffic load 3,5 KN/m <sup>2</sup> acc. to DIN 1055 Part 3		Thickness (mm)	Weight (Kg/m <sup>2</sup> )
		for 2-sided support	for 4-sided support		
		$l_s$ (m)	$l_s$ (m)		
B.444 *	3	0,30	0,90	27	60,0
B.454 *	3	0,40	1,00	29	65,0
B.464 *	3	0,60	1,15	32	70,0
B.474 *	3	0,95	1,40	35	77,5
B.484 *	3	1,40	1,80	39	87,5
B.4884*	3	1,70	-	60	135,0

\* If the edges of the pane are free we recommend the use of at least glass configuration B.444.

<b>Recommendations for max. installation size in the case of 4-sided support</b>	
Glass type	max. size in mm
B 444	900 x 3000
B 454	1000 x 3000
B 464	1150 x 3000
B 474	1400 x 3000
B 484	1800 x 3000

Table 2:

Glass configurations	Application class	Max. supporting width $l_s$ at traffic load 5,0 KN/m <sup>2</sup> acc. to DIN 1055 Part 3		Thickness ( mm )	Weight ( kg/m <sup>2</sup> )
		for 2-sided support	for 4-sided support		
		$l_s$ ( m )	$l_s$ ( m )		
B.444	3	0,40	1,25	27	60,0
B.454	3	0,60	1,38	29	65,0
B.464	3	0,85	1,50	32	70,0
B.474	3	1,25	1,75	35	77,5
B.484 *	3	1,60	2,00	39	87,5
B.4884	3	1,90	-	60	135,0

<b>Recommendations for max. installation size in the case of 4-sided support</b>	
Glass type	max. size in mm
B 444	800 x 3000
B 454	900 x 3000
B 464	1000 x 3000
B 474	1200 x 3000
B 484	1550 x 3000

Application classes 1 and 2 upon request

### 3. SUPPORT

The glass must always be flexibly supported. Direct contact - for example between metal and glass - should be avoided.

The support can be arranged with elastomer bearing strips. (DIN 4141).

For the tabular values bearing strips of  $b/t = 25/5$  mm are sufficient.

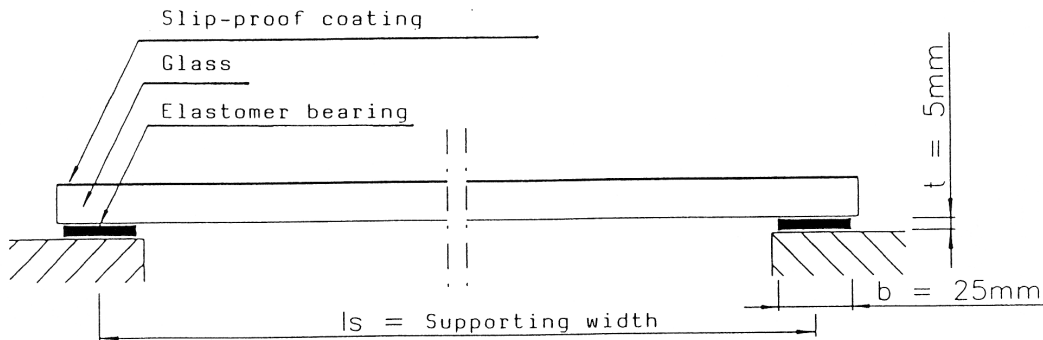

#### Further supporting examples

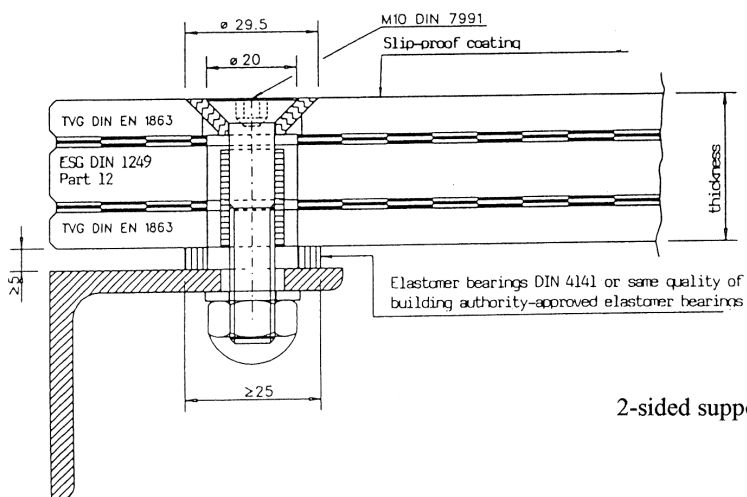

2-sided support

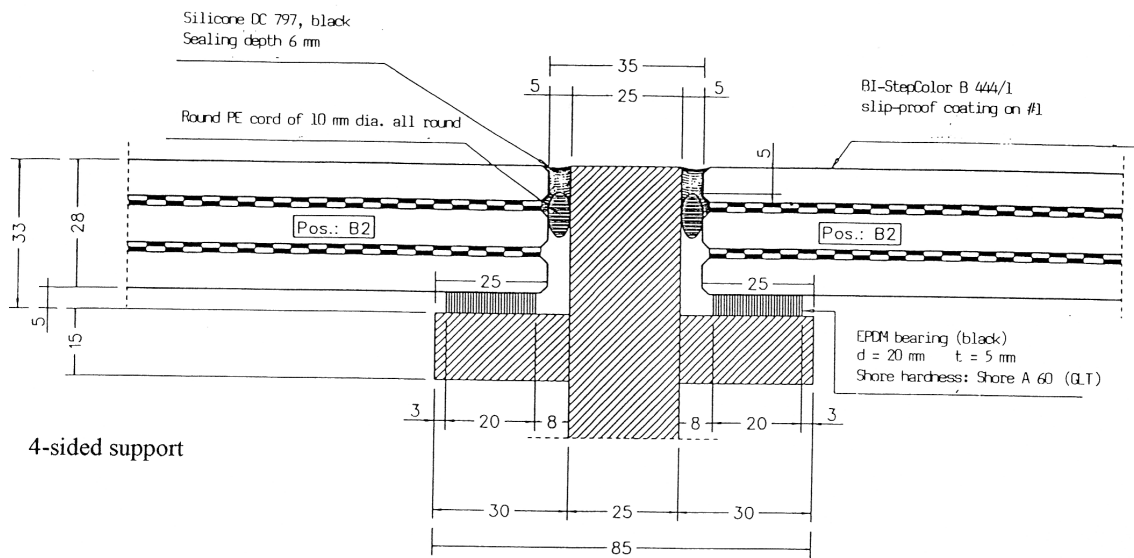

#### 4. SHOCK RESISTANCE

An essential criterion for serviceability is the surface strength, which is evaluated through the shock resistance in the case of solid hard bodies.

The shock resistance of certain selected glass configurations has been tested by the MPA Darmstadt and the FMPA Stuttgart (see Table 2).

**Table 3:** Falling height of falling bodies in (mm) and glass combinations in which no fracture arises on the glass panes.

Glass configuration	Falling heights (in mm) for different falling bodies		
	Steel ball 1,04 kg (DIN 52338)	Leather bulb 45 kg (DIN 50 337)	Steel body 10 kg (DIN 52 343 E)
B. 464	1 400	--	--

The test results prove that **BI-StepColor** from BGT can withstand everyday use.

## 5. SLIP RESISTANCE

### 5.1 **BI-StepColor**

A product with the test mark of the trade association

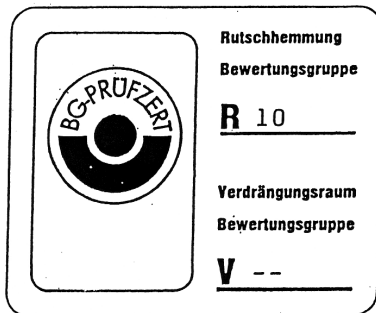

Accidents involving falling have been at the top of the accident ratings for many years according to the statistics of the Main Federation of Industrial Trade Associations. They are influenced for example by the material and surface structure of the floor covering and the level of contamination by slippery substances. Therefore, amongst other things, the accident prevention regulations also specify that floors must be installed in slip-proof designs.

The Trade Association's Institute for Safety at Work in St. Augustin - as the Main Federation of Industrial Trade Associations has tested the anti-slip coatings of BI-StepColor. In the „working safety test certificate“ the suitability of BI-StepColor as a „floor covering for use in work-rooms and working areas with increased risk of „slipping“ was confirmed. Thereby the highest demands of floor coverings were fulfilled. Individually evaluation groups between R 10 and R 11 were achieved, which makes it possible for example to use it in rooms used for edible fat manufacture or the wet areas in the food and drinks industry. Thereby **BI-StepColor** offers a high level of safety in everyday use and also contributes to the avoidance of accidents under extreme conditions.

The slip-resistant coating is subject to negligible wear. During cleaning it is necessary to follow certain regulations. We recommend the installation of BI-StepColor units with anti-slip coating in the internal area.

### 5.2 Measurement of sliding friction coefficients at British Ceramic Ltd.

To provide evidence of good slip resistance, trials have also been carried out abroad. Adhesion tests were carried out by British Ceramic Research Ltd. in England according to the respective regulations. Both completely coated and partially-coated BI-StepColor panes were tested. The coefficients of friction thus determined, which are meaningful for the assessment of slip-resistance, were found in both dry and wet tests to be between 100 and 250 % above the required value of 0,4. It was thus confirmed that it can be assumed that the tested coverings guarantee good adhesion.

Excerpt from original text of the test report

**British Ceramic Research LTD**

**APPENDIX**

**Adhesion measurements on site**

**TEST METHOD**

The measurements were carried out with a Tortus adhesion tester, which is the production version of the small mobile adhesion measurement apparatus from Ceramic Research.

The apparatus measures the dynamic adhesion coefficients between the tested panel and the slide block, which can be fitted with a heel rubber. Changes in the adhesion values are established with a portable recording device which is connected to the apparatus. The size of the slide block and the speed of movement correspond with the conditions which arise when a heel first comes into contact with the floor during normal walking.

The tests were carried out, according to requirements, in wet or dry conditions and in some cases a wetting agent was used to ensure thorough moistening of the pane and the sample. The slide block was cleaned by roughening with fine sandpaper, before each adhesion value was determined. Each measurement cycle took place over a distance of about 1 metre.

**SLIDE BLOCKS**

The material most frequently used for the slide block is hard heel rubber, which is recommended as the standard test material for adhesion tests for pedestrians.

Other materials used are:

High-quality leather,  
E.V.A. microcellular rubber, a sensitive composite material  
and soft rubber, which is also used for the T.R.R.L slip tester.

In addition to the flat slide blocks made of the above materials, angular or rounded slide blocks made of hard rubber were also used for some tests.

## **EVALUATIONS OF RESULT**

The dynamic adhesion coefficient is defined as the quotient of the horizontal force against the movement of the slide block and the vertical force of the slide block. High values show a good slip resistance and low ones on the other hand signify poor slip resistance.

Since no standard has been determined to date for the adhesion values of pedestrians, the G.L.C. has assumed generally-valid definitions. Adhesion values under 0,4 are not sufficient and values below 0,2 are dangerous.

## **NOTE**

1. The development of the measurement method is described in:

J. Phys. D: Appl. Phys., Vol. 12, 1979, S.517 - 528, and Vol. 13, 1980, L 77-79



**Table 4:** Average measured values for the sliding friction coefficients, as well as the maximum adhesion depending on the print.

Coating	Friction coefficient W with different slide block coverings and test conditions									
	Leather		Hard rubber		E.V.A. micro-cellular rubber		Polyurethene		P.V.C.	
	dry		wet		wet		wet		wet	
	Ø W.	max. W.	Ø W.	max.W.	Ø W.	max. W.	Ø W.	max. W.	Ø W.	max. W.
<b>Type A</b>	0,90	1,20	1,00	1,40	0,90	1,10	0,90	1,20	1,20	1,50
<b>Type B</b>	0,90		1,02		0,83		1,02		1,10	

Ø W = Average friction coefficient  
max. W. = Maximum friction coefficient

**Coating**

**Type A:** BGT standard décor P 11.008.33 with anti-slip coating.  
Degree of coating = 30%

**Type B:** Complete anti-slip surface

## 6. DIMENSIONAL TOLERANCES

Table 5: Tolerances for different glass configurations

Thickness of glass configuration in mm	Length tolerances in mm		Thickness-tolerances in %
	Standard ground edges	Special manufacture	
up to 18	- 2 / + 4	- 2 / + 2	+ / - 10
> 18 - 28	- 2 / + 6	- 2 / + 2	+ / - 10
> 28	- 3 / + 8	- 2 / + 2	+ / - 10

Maximum weight of individual configurations: 350 kg

Maximum length of individual configurations: 3 000 mm



Maximum width of individual configurations: 1 800 mm

## 7. DÉCOR AND COLOURS

The slip-proof coating has a matt appearance similar to a sand-blasted surface. At the same time it has extremely high transparency and is an effective light scatterer.

In order to be able to accommodate individual requirements for surface configuration the designer can choose between several surface designs.

Table 6: Décor and colours for different surface designs

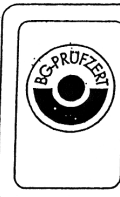
Configuration	Décor	Surface design	BG - evaluation group
B. ***/1	None	Full-surface slip-proof coating without additional colours	 <p>Rutschhemmung Bewertungsgruppe <b>R 11</b></p> <p>Verdrängungsraum Bewertungsgruppe <b>V --</b></p>
B. ***/2	All décors, which have a degree of printing > 18 % and also on a partial surface of 5 x 5 cm	Slip-proof coating is applied in the form of the selected décor	 <p>Rutschhemmung Bewertungsgruppe <b>R 10</b></p> <p>Verdrängungsraum Bewertungsgruppe <b>V --</b></p>
B. ***/3	All décors	Full surface slip-proof coating with selected coloured décor beneath	 <p>Rutschhemmung Bewertungsgruppe <b>R 11</b></p> <p>Verdrängungsraum Bewertungsgruppe <b>V --</b></p>